

FASTEKS® NAVOJNI VLOŽKI

Navojni vložki iz jekla ali iz nerjavečega jekla FASTEKS® ustvarijo natančne notranje navoje z dolgo življenjsko dobo pri obdelovancih iz lahkih zlitin in drugih materialov z nizko strižno trdnostjo.

FASTEKS® THREAD INSERTS

FASTEKS® steel or stainless steel thread inserts create precise, durable internal threads in workpieces made of light metal alloy and other materials with low shear resistance.

NAJVIŠJA – PROFESIONALNA
KAKOVOST PO PRIMERNIH
CENAH.

Dokazana vrhunska kakovost, idealne lastnosti izdelka in hitra, močna in varna montaža potrjujejo FASTEKS® kot optimalno alternativo. In seveda tudi najbolj ekonomično.

Proven top quality, ideal product properties, and installation that is fast, solid and secure make FASTEKS® the optimal alternative. And the most economically efficient one as well.



fasteks®

NAVOJNI VLOŽKI S PREČNO IZVRTINO THREAD INSERTS WITH CUTTING SLOT

FASTEKS® | NAVOJNI VLOŽKI
FASTEKS® | THREAD INSERTS

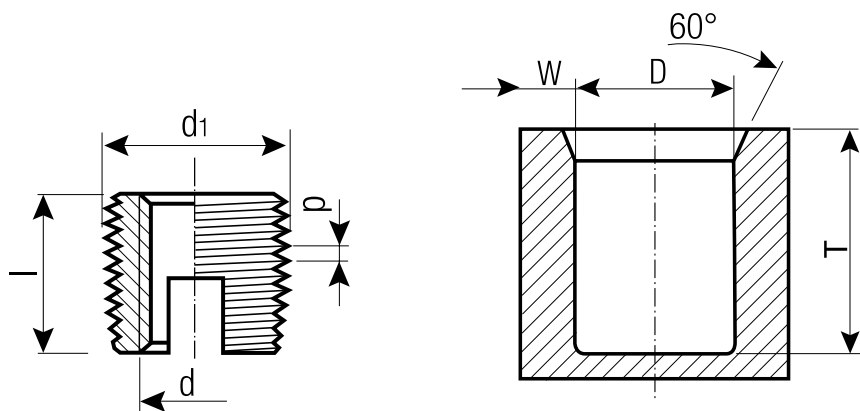

Dodatni tipi na zahtevo
Additional types on request

Material

Cementirano jeklo, pocinkano, rumeno kromatirano, skladno z RoHS

Material

Case-hardened steel, zinc-plated, yellow chromated, conform to RoHS

Oznaka za naročilo Order description	Navojni vložek* Thread insert*				Izvrtnina za montažo** Location hole**					
	d	l	d ₁	p	T _{min}	D Kovina Metal	D Plastika Plastic	W _{min} Lahke zlitine Light alloys	W _{min} Železne litine Cast iron	W _{min} Plastika Plastic
FTI02M3ST	M3	6	5	0,5	8	4,7 - 4,8	4,6 - 4,7	1,00	1,50	1,25
FTI02M4ST	M4	8	6,5	0,75	10	6,1 - 6,2	6,0 - 6,1	1,30	1,95	1,63
FTI02M5ST	M5	10	8	1	13	7,5 - 7,6	7,3 - 7,5	1,60	2,40	2,00
FTI02M6ST	M6	14	10	1,5	17	9,2 - 9,4	8,9 - 9,2	2,00	3,00	2,50
FTI02M8ST	M8	15	12	1,5	18	11,2 - 11,4	10,9 - 11,2	2,40	3,60	3,00

Material

Nerjaveče jeklo 1.4305

Material

Stainless steel 1.4305

Oznaka za naročilo Order description	Navojni vložek* Thread insert*				Izvrtnina za montažo** Location hole**					
	d	l	d ₁	p	T _{min}	D Kovina Metal	D Plastika Plastic	W _{min} Lahke zlitine Light alloys	W _{min} Železne litine Cast iron	W _{min} Plastika Plastic
FTI02M3ST SS43	M3	6	5	0,5	8	4,7 - 4,8	4,6 - 4,7	1,00	1,50	1,25
FTI02M4ST SS43	M4	8	6,5	0,75	10	6,1 - 6,2	6,0 - 6,1	1,30	1,95	1,63
FTI02M5ST SS43	M5	10	8	1	13	7,5 - 7,6	7,3 - 7,5	1,60	2,40	2,00
FTI02M6ST SS43	M6	14	10	1,5	17	9,2 - 9,4	8,9 - 9,2	2,00	3,00	2,50
FTI02M8ST SS43	M8	15	12	1,5	18	11,2 - 11,4	10,9 - 11,2	2,40	3,60	3,00

* **Tolerance:** Notranji in zunanji navoji ustrezajo toleranci ISO 2 (6H), ostale mere pa razredu ISO 2768-m.

* **Tolerances:** Internal and external threads conform to Tolerance ISO 2 (6H), further dimensions ISO 2768-m.

** **Podatki za montažo:** Prosimo, upoštevajte, da predstavljajo navedene mere v mm standardne mere in da lahko odstopajo v odvisnosti od materiala odlitka. Pred serijsko proizvodnjo je priporočeno izvesti preizkuse.

** **Installation data:** Please note that the mm dimensions quoted represent standard values and may vary depending on the material of the molded part. It is advisable to run trials prior to series production.

NAVOJNI VLOŽKI Z ZAREZO

THREAD INSERTS WITH CUTTING HOLES

FASTEKS® | NAVOJNI VLOŽKI
FASTEKS® | THREAD INSERTS

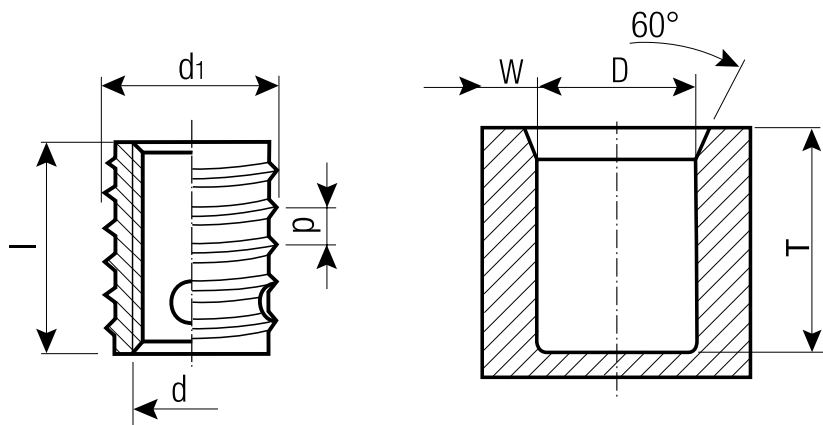

Dodatni tipi na zahtevo
Additional types on request

Material

Cementirano jeklo, pocinkano, rumeno kromatirano, skladno z RoHS

Material

Case-hardened steel, zinc-plated, yellow chromated, conform to RoHS

Oznaka za naročilo Order description	Navojni vložek* Thread insert*				Izvrtnina za montažo** Location hole**					
	d	l	d ₁	p	T _{min}	D Kovina Metal	D Plastika Plastic	W _{min} Lahke zlitine Light alloys	W _{min} Železne litine Cast iron	W _{min} Plastika Plastic
FTI02M3ST	M3	6	5	0,5	8	4,7 - 4,8	4,6 - 4,7	1,00	1,50	1,25
FTI02M4ST	M4	8	6,5	0,75	10	6,1 - 6,2	6,0 - 6,1	1,30	1,95	1,63
FTI02M5ST	M5	10	8	1	13	7,5 - 7,6	7,3 - 7,5	1,60	2,40	2,00
FTI02M6ST	M6	14	10	1,5	17	9,2 - 9,4	8,9 - 9,2	2,00	3,00	2,50
FTI02M8ST	M8	15	12	1,5	18	11,2 - 11,4	10,9 - 11,2	2,40	3,60	3,00

Material

Nerjaveče jeklo 1.4305

Material

Stainless steel 1.4305

Oznaka za naročilo Order description	Navojni vložek* Thread insert*				Izvrtnina za montažo** Location hole**					
	d	l	d ₁	p	T _{min}	D Kovina Metal	D Plastika Plastic	W _{min} Lahke zlitine Light alloys	W _{min} Železne litine Cast iron	W _{min} Plastika Plastic
FTI02M3ST SS43	M3	6	5	0,5	8	4,7 - 4,8	4,6 - 4,7	1,00	1,50	1,25
FTI02M4ST SS43	M4	8	6,5	0,75	10	6,1 - 6,2	6,0 - 6,1	1,30	1,95	1,63
FTI02M5ST SS43	M5	10	8	1	13	7,5 - 7,6	7,3 - 7,5	1,60	2,40	2,00
FTI02M6ST SS43	M6	14	10	1,5	17	9,2 - 9,4	8,9 - 9,2	2,00	3,00	2,50
FTI02M8ST SS43	M8	15	12	1,5	18	11,2 - 11,4	10,9 - 11,2	2,40	3,60	3,00

* **Tolerance:** Notranji in zunanji navoji ustrezajo toleranci ISO 2 (6H), ostale mere pa razredu ISO 2768-m.

* **Tolerances:** Internal and external threads conform to Tolerance ISO 2 (6H), further dimensions ISO 2768-m.

** **Podatki za montažo:** Prosimo, upoštevajte, da predstavljajo navedene mere v mm standardne mere in da lahko odstopajo v odvisnosti od materiala odlitka. Pred serijsko proizvodnjo je priporočeno izvesti preizkuse.

** **Installation data:** Please note that the mm dimensions quoted represent standard values and may vary depending on the material of the molded part. It is advisable to run trials prior to series production.

TEHNOLOGIJA VEZNIH ELEMENTOV IN TESNJENJA KVT

KVT FASTENING AND SEALING TECHNOLOGY



› KOENIG-EXPANDER® Čepi
KOENIG-EXPANDER® Plugs



› Vgradne-kovične matice
Blind rivet nuts



› Tehnologija slepega
kovičenja | Blind rivet
technology



› Navojni vložki
Thread inserts



› Vtisni vezni elementi
Self-clinching fasteners



› Vezni elementi za varjenje
Stud welding systems



› Varovalne matice
Lock nuts



› Vezni elementi za
kompozitne materiale
Bonding fasteners



› Zapirala
Access solutions



› Hitri vezni elementi in
sponke | Quick fastening
elements and clips



› Elementi za aretiranje in
vzmetni vijaki | Quick release
pins and spring plungers



› Lepila in tesnilne mase
Adhesives and sealants



› Vezni elementi za
gradbeništvo¹⁾
Construction fasteners¹⁾



› Posebni procesi
Special processes



› Ojačevalniki tlaka
Pressure intensifiers



› Industrijska vijačna
tehnologija
Screw technology



› Instalacijska oprema
Installation technology



› Hitre spojke in adapterji¹⁾
Quick connectors¹⁾

¹⁾ Ni na razpolago v Sloveniji. | *Not available in Slovenia.*

KVT-Fastening AG
Dietikon/Zürich | Švica
info-CH@kvt-fastening.com
www.kvt-fastening.ch

KVT-Fastening GmbH
Illerrieden | Nemčija
info-DE@kvt-fastening.com
www.kvt-fastening.de

KVT-Fastening GmbH
Asten/Linz | Avstrija
info-AT@kvt-fastening.com
www.kvt-fastening.at

KVT-Fastening Sp. z o.o.
Warszawa | Poljska
info-PL@kvt-fastening.com
www.kvt-fastening.pl

KVT-Fastening S.R.L.
București | Romunija
info-RO@kvt-fastening.com
www.kvt-fastening.ro

KVT-Fastening spol. s.r.o.
Bratislava | Slovaška
info-SK@kvt-fastening.com
www.kvt-fastening.sk

KVT-Tehnika pritrjevanja d.o.o.
Ljubljana | Slovenija
info-SI@kvt-fastening.com
www.kvt-fastening.si

KVT-Fastening s.r.o.
Brno | Republika Češka
info-CZ@kvt-fastening.com
www.kvt-fastening.cz

KVT-Fastening Kft.
Budapest | Madžarska
info-HU@kvt-fastening.com
www.kvt-fastening.hu

Za nadaljnje informacije prosimo obiščite:
For further information please visit:



› www.kvt-fastening.si

fasteks®

KVT
SOLUTIONEERING GROUP